

Wavin HepvO[®] Self-Sealing Waste Valve

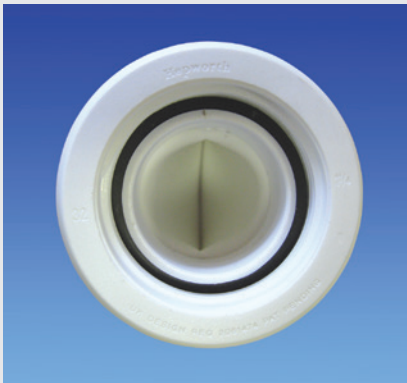

Introduction to HepvO®

HepvO® is a unique self-sealing waste valve that prevents the escape of foul sewer air from waste discharge systems, and actively maintains the pressure equilibrium in soil and waste installations. As a dry sealing valve, HepvO® utilises a purpose designed membrane to create an airtight seal between the living space and the drainage system. The self-sealing valve opens under the water pressure of an appliance emptying, and closes to form a tight seal after the appliance has discharged under normal atmospheric conditions.



Benefits

The HepvO® dry self-sealing valve offers a number of benefits for both the professional installer and end user of the product. In addition, HepvO® offers considerable benefits for the system designer. See the System Design section of this document for further information.

- ⦿ The HepvO® valve promotes hygiene, particularly where an appliance is infrequently used.
- ⦿ HepvO® differs from conventional traps, which can dry out or hold water which can become stagnant causing the emission of smells and enhancing bacterial growth – see Figure 1 below.
- ⦿ HepvO® actively eliminates negative pressure within the waste system by opening and allowing in fresh air until a state of equilibrium with atmosphere is reached. It subsequently closes to reseal the waste system and prevent foul air release. This means the venting of the waste system is improved and it is no longer necessary to fit an air admittance valve.
- ⦿ The HepvO® valve results in enhanced plumbing design and system efficiency. Unlike water seal traps, HepvO® is not affected by siphonage and will therefore not allow the escape of foul air into the living space from drain or sewer. The compact design and different installation options make HepvO® a very effective space-saving device.
- ⦿ HepvO® allows discharge water to pass easily through, regardless of the volume.
- ⦿ HepvO® allows the placement of a greater number of appliances together on fewer discharge pipes without compromising the performance of the sanitary discharge system.
- ⦿ HepvO® operates silently and is not subject to “gurgling” noises typically associated with siphonage and indicative of a breach in the water seal barrier. Independent tests confirm that HepvO® performs silently when subjected to a range of abnormal pressures.

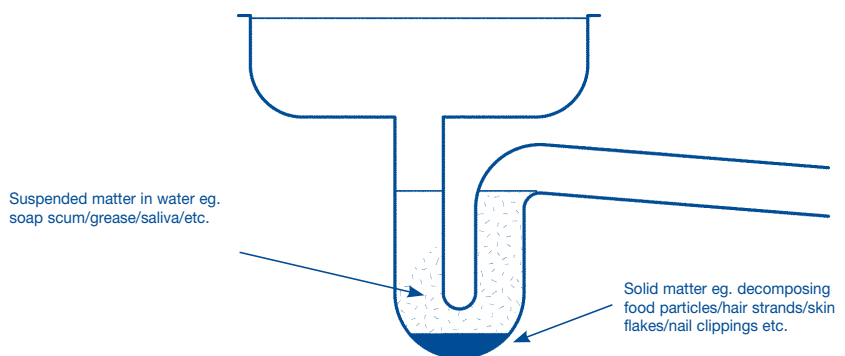

Figure 1. Water held in conventional traps can become stagnant.

- Even when hot or cold fats are released into it, a HepvO® valve continues to perform, compared to conventional traps where a solid plug of fat forms within the trap as the fat comes into contact with the cold water held in the trap.
- The HepvO® valve will perform under back pressures which are 10 times greater than those experienced in a typical soil and waste system.

Water seal weaknesses

In summary, HepvO® will not fail under any of the conditions shown below in Figure 2.

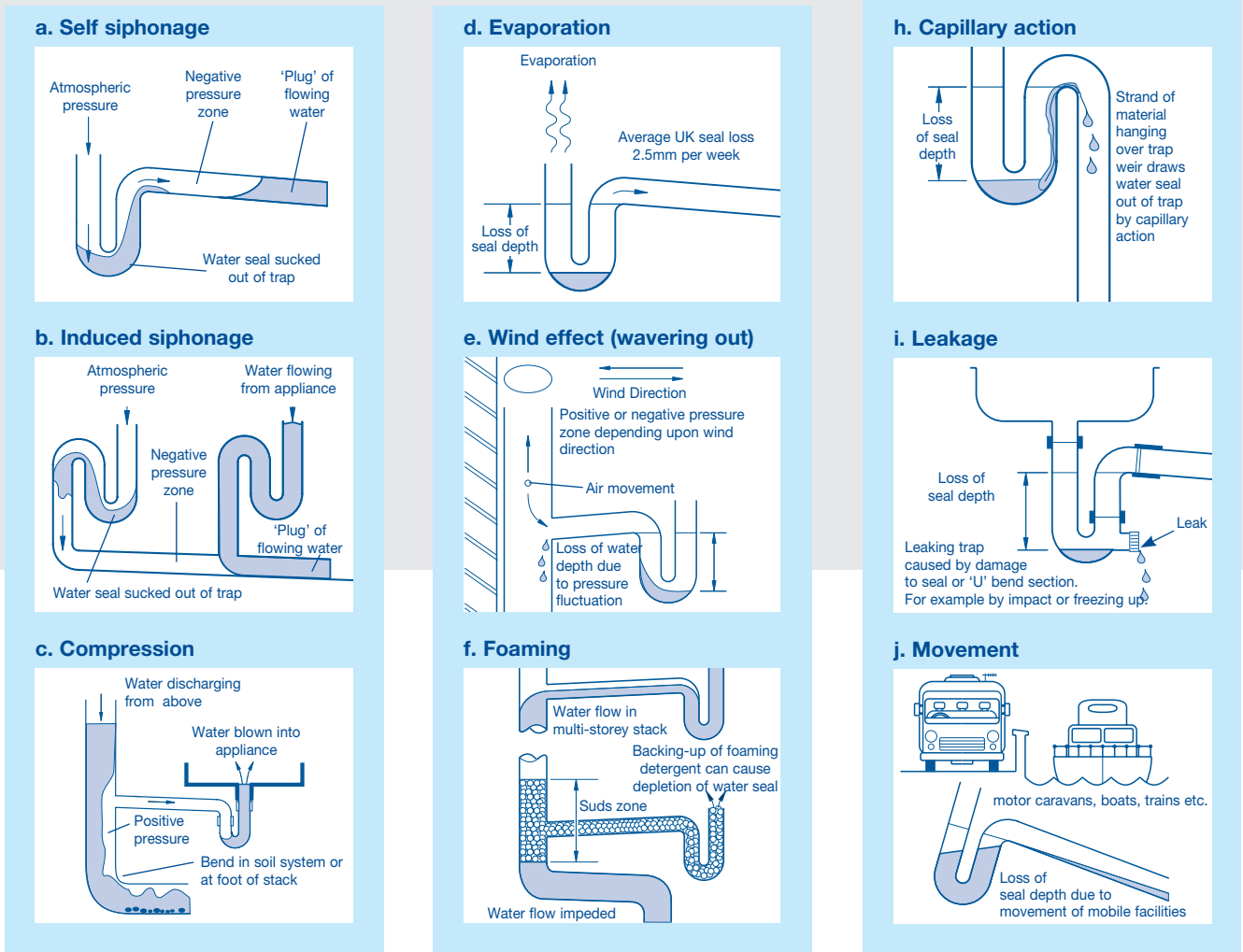

Figure 2. Ten potential reasons for trap failure.

Applications

HepvO® can be used more effectively than a conventional trap in domestic situations, including marine and mobile home installations (see Figure 2j).

A self-sealing waste valve is a suitable alternative for traditional waste traps on any waste appliance and on all types of sanitary systems such as primary ventilated systems (formerly known as “single stack”) and secondary ventilated systems, stub stacks, and where appliances connect to a gully. In addition, HepvO® can be used in a number of other applications:

- ⦿ In conjunction with HepFlex® Waste flexible waste pipes and connectors, as well as with traditional rigid waste systems.

- ⦿ Acts as an air admittance valve, allowing air into the drainage system when negative pressure occurs.
- ⦿ Once a state of equilibrium is met the valve closes. Using the valve as an air admittance tool provides cost savings, as it eliminates the need for a traditional open vent pipe or an air admittance valve to be positioned on the stack in certain circumstances.
- ⦿ With an unvented hot water storage system to connect a tundish outlet pipe to a drainage stack. This stops the admission of foul air from drainage systems into premises.

- ⦿ Condensate from air conditioning units can be discharged directly through HepvO® to a drainage stack without risk of odour ingress.



System design

It is a mandatory requirement of the UK Building Regulations Document H and other national building regulations that a drainage system does not allow foul air from the drainage system to enter the building under working conditions.

Primary ventilated soil and waste discharge systems, will be subject to negative and positive pressures as water is discharged from associated sanitary appliances. These pressure fluctuations may result in self siphonage, induced siphonage or compression (see Figure 2 a,b,c). These positive and negative pressure fluctuations can cause water trap seal reduction, for example, reducing a wash hand basin trap from 75 mm to 25 mm. Systems which deviate from the regulations will be subject to greater pressure fluctuations which commonly result in water dis-

placement out of the trap allowing foul air to enter the building. Foul sewer air is undesirable and must not be tolerated. A water seal trap which is not protecting people from the entry of sewer air can be identified by either a Gurgling Noise and/or a Foul Drain Smell. The performance of the valve in excluding foul air is unaffected by those pressures normally found in domestic and commercial soil and waste systems.

HepvO® removes the risk of the escape of foul sewer air that exists when using conventional traps. Excessive positive pressures will be relieved by air bubbles escaping through any WC water seal within the system. However, should abnormally excessive internal pressures exceed 500mm water gauge (0.5 bar), then the valve element of HepvO® will invert, indicating high pressures

exist within the soil and waste system. Another indicator is that water will back-fill the appliance, thereby giving an important safety warning that there is a problem within the system, and investigation is required. HepvO® allows the designer to place a greater number of appliances together on fewer discharge pipes without compromising the performance of the sanitary discharge system.

Design freedom and economic benefits

Current regulations for waste system design set limits on length and gradient of pipes and the number of appliances which can be connected to a waste pipe in order to keep pressure fluctuations to a minimum. This may be rectified by the incorporation of vent pipes at appropriate design locations.

The incorporation of HepvO® increases the designers' scope for the reasons listed opposite, whilst providing a good sanitary system offering a minimum resistance to flow, as stated in BS EN 12056: Part 2.

1. Full bore flow can be a benefit where HepvO® is fitted to all appliances – see Figure 3. Full bore flow provides better self-cleansing, which means that smaller diameter waste pipe branches can be considered without fear of siphonage from traditional water-filled traps. This can also save space and cost.
2. Anti-siphon piping and valves are not required for waste appliances.
3. Auxiliary venting is not required for ranges of waste appliances.
4. There is no maximum limit on waste pipe slopes.
5. Branches connecting waste appliances to a common pipe do not need to be swept at 45 degrees.
6. Where necessary, tight radius bends can be used without fear of siphonage or compression.

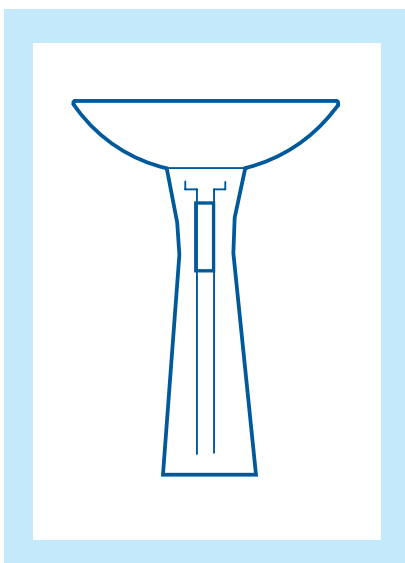

Figure 4. Hep_vO in a slimline pedestal.

Time saving

HepvO® allows for simpler systems with less pipework & straight runs – see Figure 3. On completion of the installation, there is no need to perform self siphonage and induced siphonage tests for branch discharge pipes from waste appliances.

Space saving

Where required, the waste pipe can drop in a straight line from the appliance

outlet which means that installation access for slimline pedestals is significantly enhanced – see Figure 4.

For kitchen sinks, HepvO® can be offset to the back wall after a short run of waste pipe from the appliance outlet which opens up the cupboard space below the sink – see Figure 5. HepvO® can be installed horizontally by using the 87,5° adaptor, which avoids cutting the floor under baths and showers to accommodate the 'U' bend of a trap – see Figures 10 & 11. It also ensures the correct minimum drainage slope.

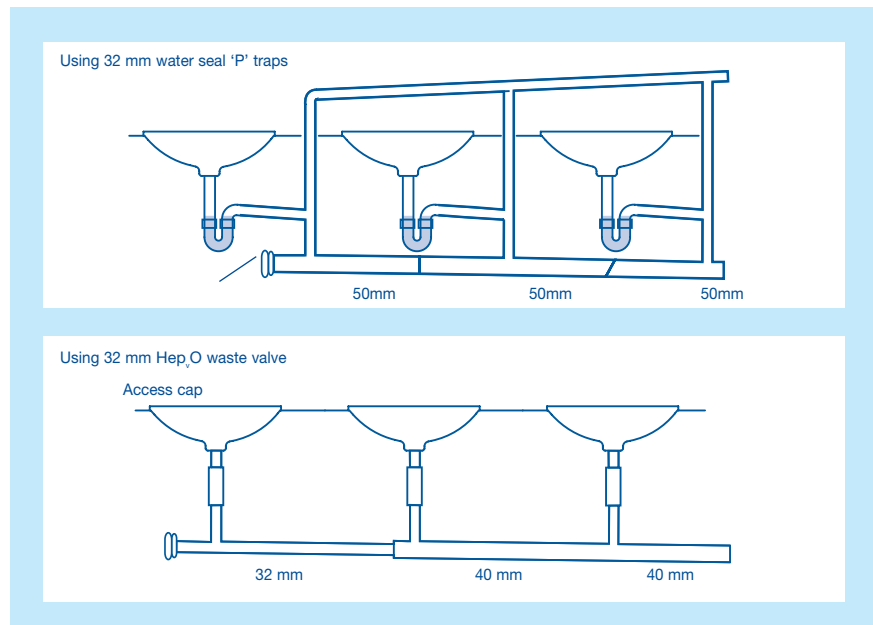

Figure 3. Schematic view for three basins.

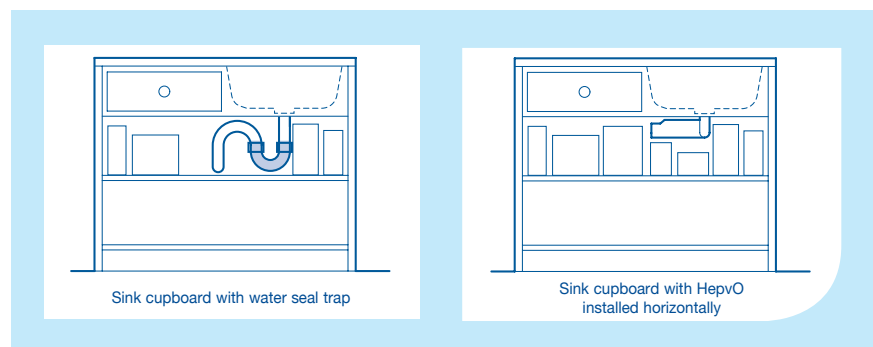

Figure 5. Space saving capabilities under a kitchen sink.

As house designs become more creative and complex, they create greater potential within the system for pressure fluctuations and trap failure.

Example:

Adjacent bathroom and en-suite. In Figure 6, a conventional water seal trap would be liable to failure as a result of pressure fluctuations. Use of the HepvO® valve in this design would relieve negative pressure changes and maintain an effective seal between each waste appliance and the drainage system.

Example:

An unvented hot water storage system. In Figure 7, the HepvO® valve is used in conjunction with a combined temperature and pressure relief valve. The hot water is discharged through the HepvO® valve. In this application, the discharge pipe should only be of either polypropylene to BS EN 1451 Part 1 or copper.

In a similar way the condensate from an air conditioning unit may be discharged through a HepvO® directly to a drainage stack.

Ventilation

Care should be taken to ensure that the underground drainage system is not completely sealed. Natural open ventilation is required at the head of each main drain run and/or at every tenth dwelling.

Figure 7. Self-sealing valve when used with a combined temperature and pressure relief valve for unvented hot water storage system.

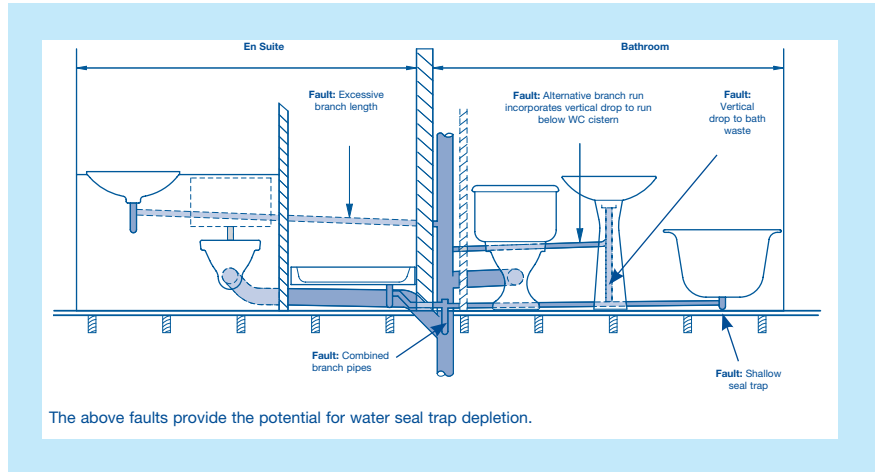
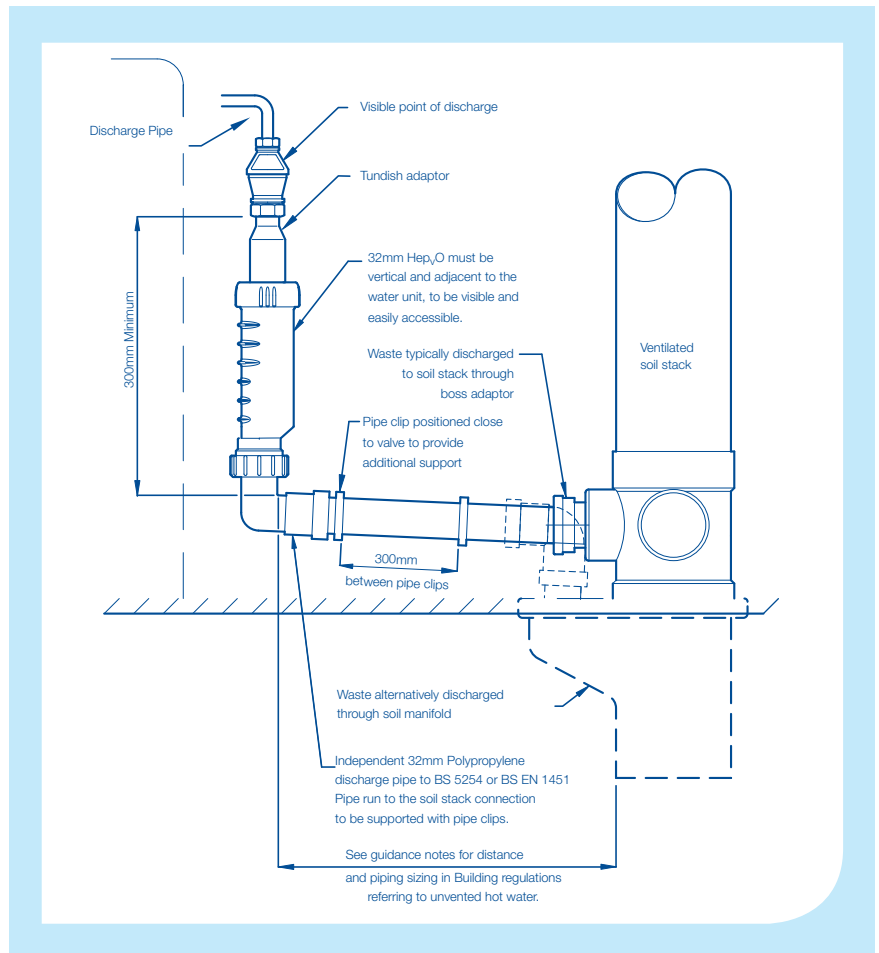

Figure 6. Problems leading to trap failure within a typical bathroom and en-suite arrangement Installation requirements often dictate pipework is outside the design limitations of BS EN 12056 Part 2.



Installation

HepvO® should be installed in accordance with the instructions given here.

Orientation

When fixed horizontally to an appliance outlet or to a sloping pipe HepvO® must be installed with the ribs underneath – see Figure 8. This prevents standing water and provides a continuous fall when used in combination with the HepvO angled adapter.

HepvO® inlet

The inlet is provided with a screwed cap and sealing ring, designed to connect to waste fittings conforming to BS EN 274, or to a HepvO® inlet adaptor.

Joining

Offer up the HepvO® inlet to the threaded tail of the appliance waste outlet or HepvO® knuckle or running adaptor, and tighten the threaded cap sufficiently hand-tight to provide a water-tight seal (check that the cap screws on square and does not 'cross-thread'). When the screwed cap is tight, the HepvO® body is secure.

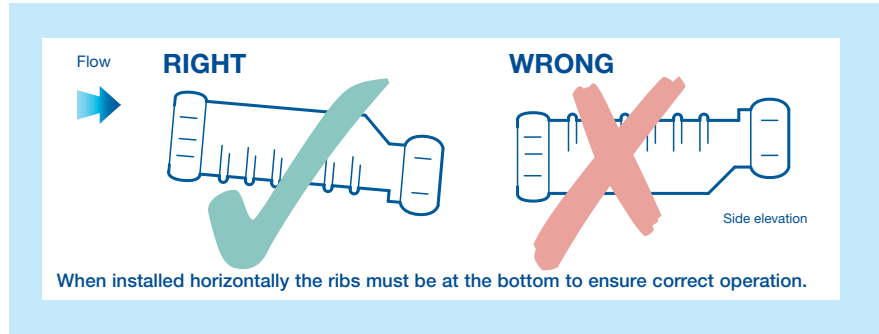

HepvO® outlet

The outlet is provided with a universal compression connection which is designed for use with (1) 'UK Metric' 32 or 40mm waste pipes to BS EN 1451 Part 1 (or equivalent) or (2) 'DN Metric' 32 or 40 mm waste pipes.

Joining

1. Cut the pipe to length, allowing for the full compression socket depth (using an appropriate pipe cutter, such as a Hepworth ratchet pipe cutter).

Figure 9. HepvO® outlet connection.

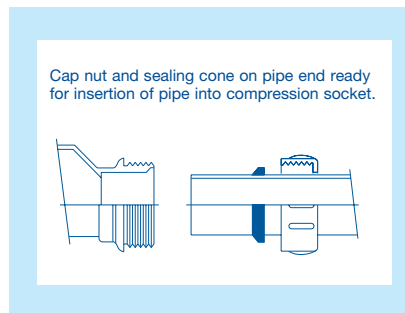

2. Remove any 'swarf' from the end of the plastic pipe. Ream the copper pipe end to remove any 'burr', and file if necessary to remove any external sharp edges. Mark the socket depth on the pipe, and check that the pipe section to be jointed is free of any surface damage which may affect the joint seal.
3. Unscrew the cap from the HepvO® outlet, and slide the cap and rubber seal onto the pipe – see Figure 9.
4. Insert the pipe end fully into the socket.
5. Slide the rubber seal and screwed cap up against the face of the socket, and tighten the cap sufficiently hand-tight (check that the cap is square to the body and does not 'cross-thread').



NOTE:

Do not use any jointing compound or sealant on the HepvO® inlet or outlet connections.

NOTE:

For connection to other pipe sizes (for example 50 mm) it is possible to make threaded connections to pipe adapters at the HepvO® Inlet and Outlet. In the case of the Outlet it is then necessary to discard the compression joint components and use Teflon tape before making connection onto the male threads.

HepvO® can be used on any waste appliance. The installation arrangement will depend on the dimensional design of the appliance and site constraints.

Figure 10 shows some of the mounting options for HepvO®. HepvO® can be fixed directly to the waste outlet of an appliance. By using the appropriate adaptor it can also be mounted in the horizontal position either at the appliance or on the pipe.

HepvO® should ideally be fitted vertically. If a HepvO® valve is fitted horizontally, it should be in combination with the HepvO® angled adaptor to ensure correct minimum drainage slope or connected to pipework with a drainage slope no less than 18 mm per metre.

Waste piping

Waste pipes should have sufficient slope to convey the likely flow, but should not be less than 18 mm/metre in accordance with BS EN 12056 Part 2 or equivalent local regulations. When using HepvO® there is no maximum slope limitation – often a restriction applicable to single stack waste systems.

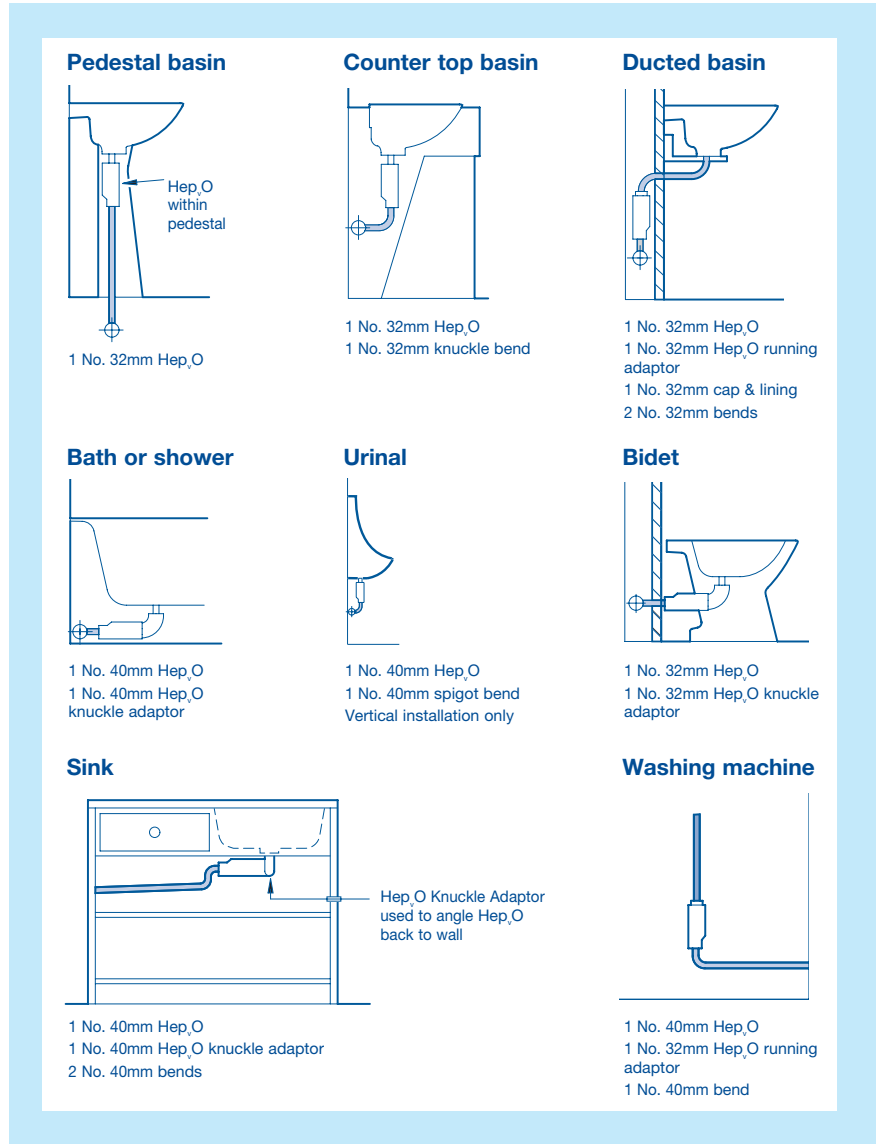

Figure 10. HepvO® mounting options.

As HepvO® is unaffected by siphonage or compression, combined waste piping can be used to connect more than one appliance to the stack. Figure 11 shows how HepvO® can be used to simplify the plumbing to a typical bathroom.

Any branch discharge pipes serving appliances not fitted with HepvO® (eg. a range of WC's) should be designed and installed in accordance with BS

EN 12056 Part 2 or equivalent local regulations.

Discharge stacks should continue to be sized, and vented where appropriate, in accordance with BS EN 12056 Part 2 or equivalent local regulations.

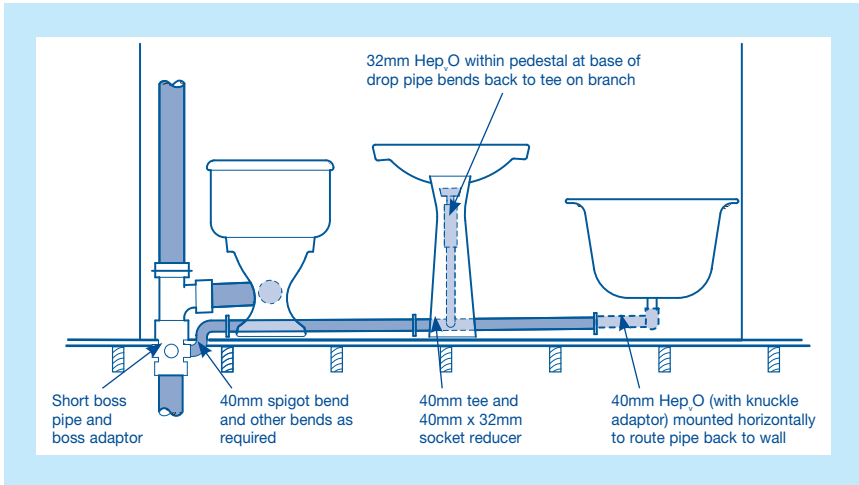

Figure 11. HepvO® installation in a typical bathroom.

NOTE:

Care should be taken to ensure that the underground drainage system is not completely sealed. Natural open ventilation is required at the head of each main drain run and/or at every tenth dwelling.

Operation and maintenance

Operation

HepvO® operates as illustrated in Figure 12 below. The membrane opens when there is a small positive pressure difference between the inlet and the outlet, for example when a small quantity of water flows into the inlet side. It closes immediately when that pressure difference is negated ie when the water

has discharged through the valve. The membrane remains closed in the event that the pressure is higher at the outlet compared to the inlet, resisting sewer odour and back-up of liquid waste. Long term cycle testing and installation experience show that there is no deterioration in valve sealing performance after in excess of one million opening and closing cycles.

Maintenance

If mechanical devices such as spiral cables, rippers or water jetters are required to clear blockages in the waste system, the HepvO® valve must be removed first. It is good practice to rinse the HepvO valve with a little clean water before replacing it in the system. Drain cleaning chemicals may be used directly without the need to remove the HepvO® valve.

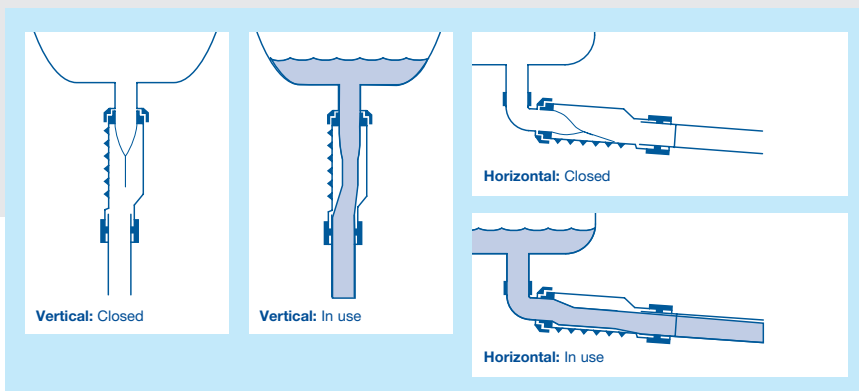

Figure 12. Operation of HepvO®.

Product detail

The HepvO® valve and knuckle adaptors are available in sizes 32 mm and 40 mm. The HepvO® tundish adaptor kit comprises a 32 mm HepvO® valve and tundish adaptor. A 87.5° knuckle adaptor should be used with the HepvO® valve for horizontal applications, and an in-line adapter when installed the HepvO® in a pipe run. All items are manufactured from white polypropylene. Dimensional data for the HepvO® is shown in Figure 13 below.

HepvO® dimensional data

Figure 13. Principle dimensions (mm).

SIZE	C	E	L	W	Z	H
32 mm	8	171	208	211	40	70
40 mm	5	171	208	213	40	73

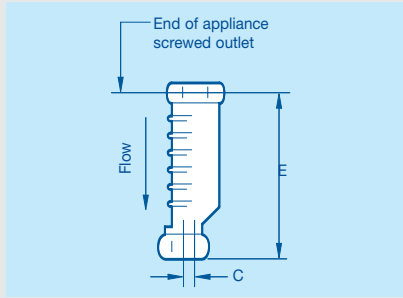

a) Fixed vertically directly to appliance outlet

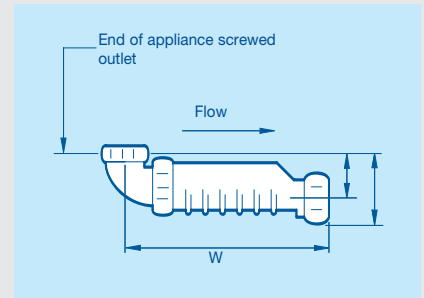

c) Fixed horizontally to appliance outlet using knuckle adaptor (available separately)

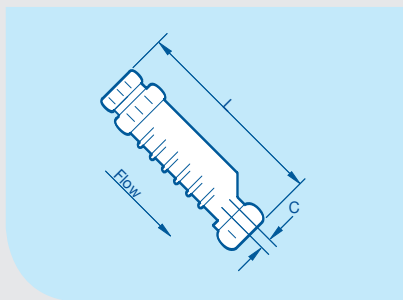

b) Fixed on a pipe at any sloping angle using an in-line adapter (available separately)

Notes:

1. Dimensions are nominal and may vary slightly due to compression of the rubber seals.
2. When fixed to a pipe, it is recommended that HepvO® should remain accessible.

System	Inlet Pipe Size (Nominal)	Inlet OD Pipe Size (actual)	Valve Part No	Angled Adapter	In-Line Adapter	Threaded Valve Inlet	Valve Outlet
UK	32 mm	34.5-36.5	BV1 WH	BV11 WH	BV3 WH	1 1/4"	UK 32 mm Pipe
UK	40 mm	40.9-43.2	CV1 WH	CV11 WH	CV3 WH	1 1/2"	UK 40 mm Pipe
DN Metric	32 mm	32.0-32.4	BV1/M WH	BV11 WH	BV3/M WH	1 1/4"	DN 32 mm Pipe
DN Metric	40 mm	40.0-40.4	CV1/M WH	CV11 WH	CV3/M WH	1/ 1/2"	DN 40 mm Pipe

Special versions compatible with US Tubular Pipe Systems to ASTM-F409 also available on request.

Figure 14. Parts numbers.

Quality, standards and approvals

All Hepworth branded products are manufactured under a quality management system which is approved to BS EN ISO 9001.

All Wavin manufacturing sites operate Environmental Management Systems which comply with the requirements of, and are certified to, BS EN ISO 14001.

The use of HepvO[®], when installed in accordance with manufacturers recommendations, will ensure that installations comply with the requirements of BS EN 12056 Part 2 Code of Practice for Sanitary Pipework, and Document H of the Building Regulations 2002 or equivalent local regulations.

HepvO[®] functions without the use of water and complies with all other relevant functional requirements of BS EN 274: Specification for Plastics Waste Traps.

HepvO[®] is certified by BRE, certificate number 042/97, as a satisfactory means of excluding foul air from a building within a single stack drainage system.

HepvO[®] also complies with BS EN 15749-1 2004 Ships and Marine Technology – drainage systems on ships and marine structures.

Test results indicate that the HepvO[®] valve has a life expectancy at least equivalent to current water sealed traps.

International Approvals

Australia

Watermark No 20062 to
ATS5200.047 : 2005

USA

Product Listing to ASME/ANSI
A112.18.8 : 2009

Canada

Certificate of Compliance to
TIL MSE 55 - 2009

Japan

Performance Evaluation Certificate -
Building Committee of Japan:
Evaluation No. BCJ-EV-HS0003-01
(7 January 2010)

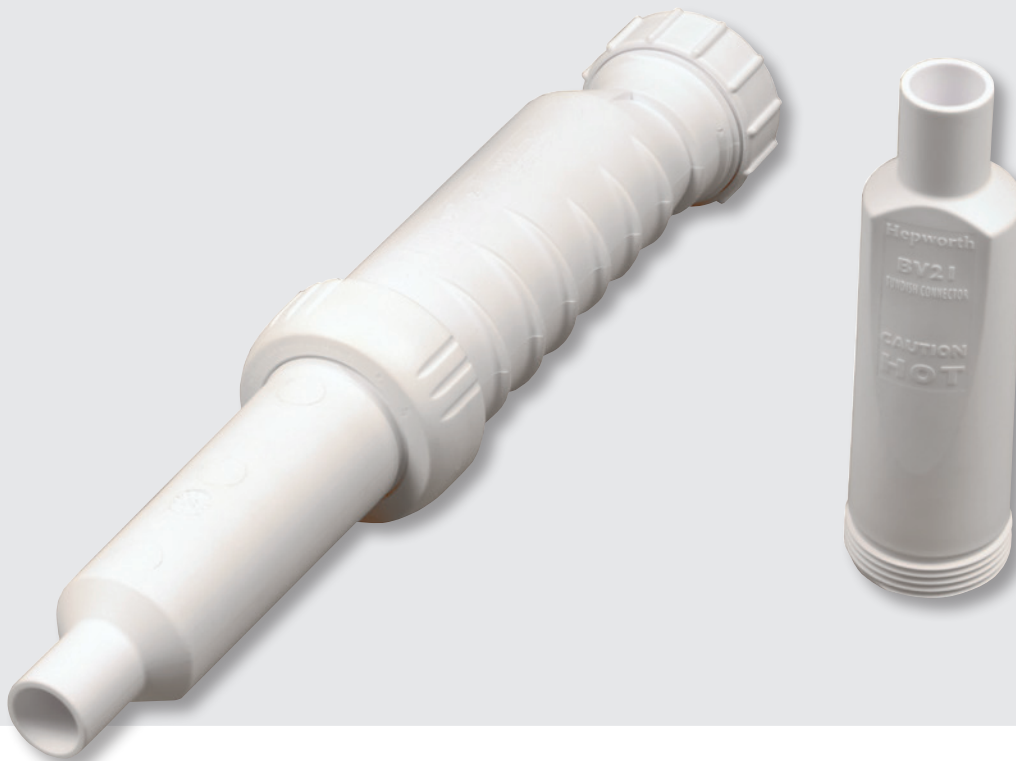

Discover our broad portfolio at
www.wavinoverseas.com
www.wavin.ae
www.wavin.asia

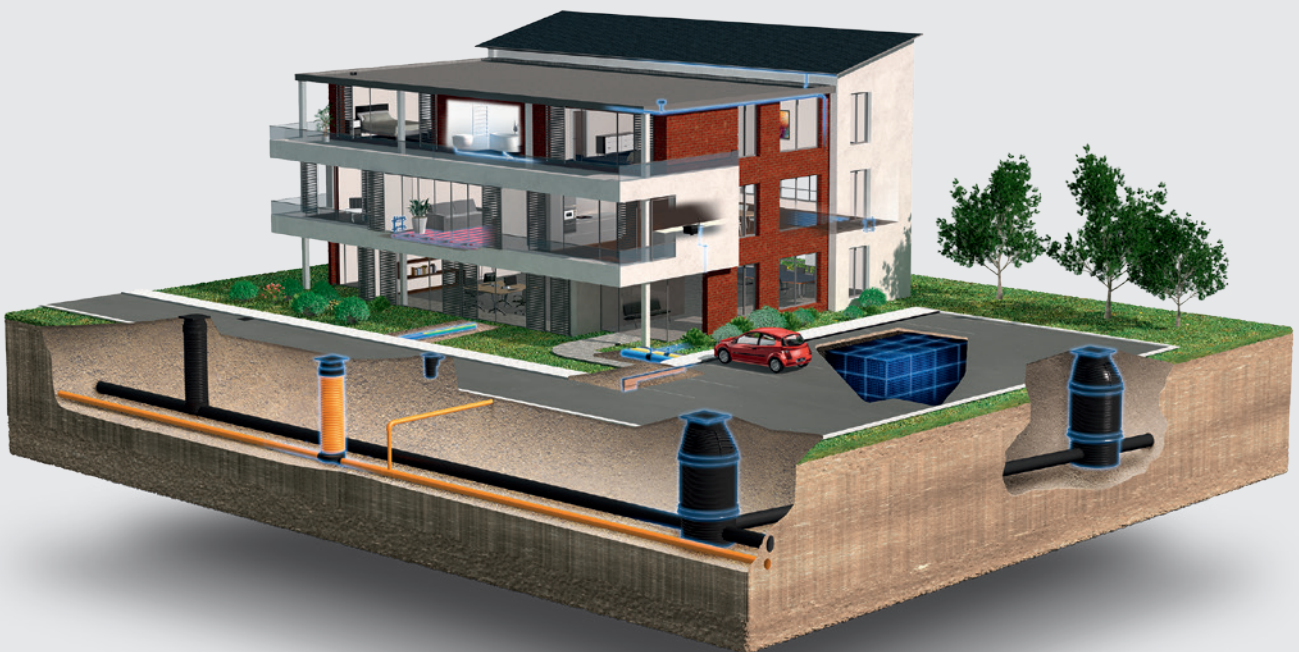

Water management | Heating and cooling | Water and gas distribution
Waste water drainage | Cable ducting

Connect to better at:

- ⦿ www.wavinoverseas.com or
- ⦿ www.wavin.ae for Middle East & North Africa
- ⦿ www.wavin.asia for Asia Pacific

Wavin operates a programme of continuous product development, and therefore reserves the right to modify or amend the specification of their products without notice. All information in this publication is given in good faith, and believed to be correct at the time of going to press. However, no responsibility can be accepted for any errors, omissions or incorrect assumptions. Users should satisfy themselves that products are suitable for the purpose and application intended.



CONNECT TO BETTER